



# U字溝用アメニティーカバー

天然石充填タイプ



標準：カシマ



スリット付：カシマ

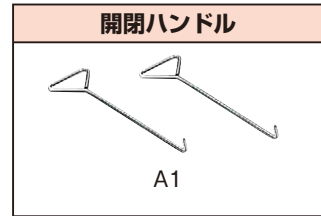

標準

**ASU**

U字溝用

CAD

スリット付

**ASU-S**

U字溝用

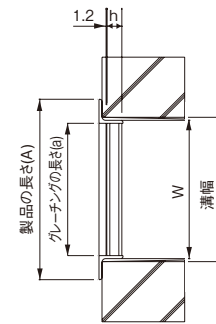
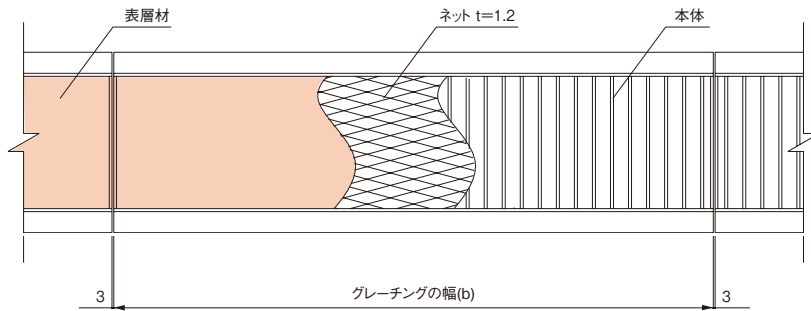

(単位：mm)

適用荷重	溝幅	型式記号	グレーチング					アングル	参考質量 (kg)	価格(円/枚)	
			幅(b)	長さ(a)	W	本体高さ (h)	製品の長さ (A)			ASU	ASU-S
歩 T-14	120	ASU25-12(S)	997	100	110	25	180	L40×40×5	12.2	15,300	16,300
	150	ASU25-15(S)	997	130	140	25	210	L40×40×5	13.7	16,700	17,700
	180	ASU25-18(S)	997	160	170	25	240	L40×40×5	15.3	18,200	19,200
	200	ASU32-20(S)	997	180	192	32	280	L50×50×6	21.0	20,100	21,100
	240	ASU32-24(S)	997	220	232	32	320	L50×50×6	23.1	22,100	23,100
	300	ASU44-30(S)	997	275	287	44	405	L65×65×6	33.2	26,800	27,800
	360	ASU50-36(S)	997	335	347	50	465	L65×65×6	42.7	34,000	35,000
歩 T-2	120	ASU19-12(S)	997	100	110	19	180	L40×40×5	11.6	14,700	15,700
	150	ASU19-15(S)	997	130	140	19	210	L40×40×5	12.4	16,200	17,200
	180	ASU19-18(S)	997	160	170	19	240	L40×40×5	13.6	17,600	18,600
	200	ASU25-20(S)	997	180	190	25	260	L40×40×5	16.6	19,300	20,300
	240	ASU25-24(S)	997	220	230	25	300	L40×40×5	18.6	19,800	20,800
	300	ASU25-30(S)	997	280	290	25	360	L40×40×5	22.0	23,800	24,800
	360	ASU32-36(S)	997	340	352	32	440	L50×50×6	30.9	27,800	28,800
歩	120	ASU19-12(S)	997	100	110	19	180	L40×40×5	11.6	14,700	15,700
	150	ASU19-15(S)	997	130	140	19	210	L40×40×5	12.4	16,200	17,200
	180	ASU19-18(S)	997	160	170	19	240	L40×40×5	13.6	17,600	18,600
	200	ASU19-20(S)	997	180	190	19	260	L40×40×5	14.4	19,000	20,000
	240	ASU19-24(S)	997	220	230	19	300	L40×40×5	15.6	19,500	20,500
	300	ASU19-30(S)	997	280	290	19	360	L40×40×5	17.9	23,700	24,700
	360	ASU19-36(S)	997	340	350	19	420	L40×40×5	20.2	27,600	28,600

## 製品情報

- スリットなしとスリット付があります。
- アメニティーカバーは歩行者の通行の安全と景観向上を目標に製造しています。従って使用場所は一般公道でなく公園、敷地内等でご使用ください。開閉用として、スリット付を10枚に1枚程度ご使用ください。
- アメニティーカバーの耐荷重は歩道用に設計してあります。適用荷重にあるT荷重は緊急車両用です。

## 注文情報

- ご注文の際、天然石をご指示ください。

